



AMERICANA

OUTDOORS

Elements for Life *Outside.*TM
SHADE • SHELTER • SPORT • SITE



WWW.AMERICANA.COM

Who We Are

Americana is a family-owned company making high-quality recreational amenities for communities across the country. Our products are American-made and engineered to meet the demands of outdoor living. From shelters and seating to sports equipment, Americana offers architects, general contractors and other clients a full range of beautiful and fully customizable furnishings to create a complete outdoor environment that helps communities *work, play and live better.*

Pillars of Distinction



Engineered for Outdoor Living

We build products for every climate, every terrain and every purpose to meet the demands of outdoor living.



Shaping an Entire Outdoor Experience

From shelters and seating to sports equipment, Americana creates complete outdoor environments that enhance the quality of life for communities, promoting productivity, leisure, and well-being.



Providing Service that Comes Naturally

At Americana everyone is family and our clients are friends. When you care about the people around you and love what you do, great and knowledgeable service just comes naturally.



2024 Edition

Contents

- 02 **Who We Are**
- 03 **Index**
- 04 **Featured Projects**
- 10 **Hip Roof Shelters**
- 12 **Monoslope Shelters**
- 16 **Split Roof Shelters**
- 18 **Gable Roof Shelters**
- 26 **Gazebo Shelters**
- 30 **Entryway Shelters**
- 36 **Walkway Shelters**
- 38 **Cantilever Shelters**
- 40 **Shade Shelters**
- 44 **Options & Accessories**
- 50 **Warranty**
- 51 **Site Furnishings**



Featured Project:
The Civic Green
Yorktown, Indiana



From Above

In the heart of downtown, Civic Green offers increased foot traffic to local business owners and better proximity to amenities for residents. With a shade/performance structure and a sensory plaza with misters and lights, Civic Green is a versatile space that can be enjoyed by residents of all ages.



Project Team

- Dealer(s): Commercial Recreation Group, Myers Construction Management
- Architect(s): Context Design, US Architects
- Engineer(s): Mark Peradotti



Products

- (2) 15' x 23.5' Single Mono-Slope Illini Shelters
- (2) 30 x 23.5' Double Mono-Slope Illini Shelters
- (1) 20 x 30 Single Mono-Slope Illini Shelter



Challenges

Civic Green is one of the most recent projects completed by Americana Outdoors, it provided us with new challenges to bring our manufacturing & engineering skills to the next level. This site features our brand new Mono Slope Illini Shelters, bringing new form and function to one of our most popular products.



Featured Project:

Utica Park Covid-19 Memorial

Frederick, Maryland



From Above

Utica Park, located in the lovely city of Frederick Maryland is now home to a unique and breathtaking Covid 19 Memorial. This memorial is a place where the community can remember those people who have died as a result of the COVID-19 pandemic, but also recognize those who may be suffering from long term impacts of COVID. It is a peaceful place to sit, relax, and reflect.



Project Team

- Dealer(s): Green Site, LLC
- Engineer(s): Mark Peradotti, Alex Yarbrough



Products

(1) 6x26' Custom Artisan Series Pergolas



Challenges

Given the parameters and footprint of this location, we were approached with the idea of a curve Pergola to fit the space. This was extremely difficult given the fact that curved structures such as this usually span much further distances, making the curve much less intense. After a lengthy design process, our engineers and skilled craftsman developed a 3x8 curved steel beam to match the specifications needed. Resulting in a very compact, elegant, and beautiful structure.

In remembrance of those who died from COVID-19 and those who suffered long-term impacts from the pandemic.

In remembrance of those who died from COVID-19 and those who suffered long-term impacts from the pandemic.



Featured Project:

GORC Park

Odenton, Maryland



From Above

GORC Park in Odenton, Maryland, where family fun takes center stage! Following renovations in 2021, the park now features two charming pavilions as its focal point, providing a perfect spot for picnics and gatherings. The surrounding playground area boasts a variety of exciting play equipment, including swings, climbing structures, slides, and more.



Project Team

- Dealer(s): Green Site, LLC
- Engineer(s): Mark Peradotti, Alex Yarbrough



Products

- (1) 16' Diameter Aztec Shelter
- (1) 24x48' Extended Navajo Shelter



Challenges

The layout and limited space at GORC Park necessitated meticulous planning to incorporate the pavilions while preserving the integrity of other recreational zones. Furthermore, a top priority was ensuring the pavilions seamlessly blended with the park's natural environment and overall aesthetics. Efficient management of construction logistics, encompassing site access and materials delivery, was vital to minimize inconvenience to park-goers. In overcoming these hurdles, the addition of the pavilions has significantly enhanced GORC Park's offerings, offering the community valuable gathering spaces to relish.



Hip Roof Shelters



Navajo & Mojave Series

The Navajo and Mojave shelters offer sleek, dependable coverage in any outdoor setting. Designed with simplicity in mind by our expert engineers, these shelters seamlessly integrate into a variety of projects.

Sizes: 12x12' minimum, extended sizes up to 40x60'.

Roof Pitch: Standard 4/12.

Optional Roof Pitch: 6/12.

Structure: Four sided pre-fabricated, powder coated steel frame.

Frame: Tubular Steel.

Standard Roof System:

Navajo Model - 24" Aluminum "W" Panel with Extruded Aluminum Gutters.

Mojave Model - 36" Galvalume "R" panel with Aluminum Edge Trim, or Optional Gutter.

Optional Roof System:

18" Galvalume Standing Seam Panel with Extruded Aluminum Gutters, or Edge Trim with T&G Wood.

8" Aluminum Roll Formed Flat Panel with Extruded Aluminum Gutters.

Tongue & Groove Wood with Shingles.

Add-On Accessories: Cupola, double tier roof, dutch hip roof, steel railing.



Monoslope Shelters

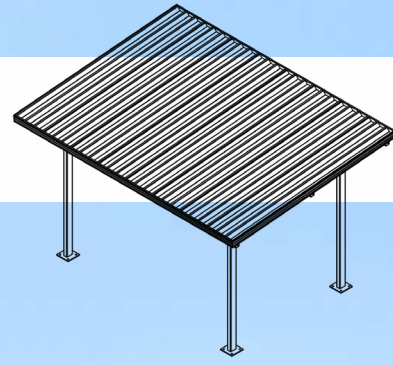

Monoslope Shelters

Presenting the Americana Monoslope Shelter: Enjoy modern, stylish defense in any outdoor setting with its unique monoslope architecture. Our expert engineers have devised an elegant, effortlessly adaptable shelter that harmoniously complements an array of projects.

Sizes: Ranging from 6-50' wide and 12-84' long.

Roof Pitch: Standard 1/12.

Optional Roof Pitch: 1/12 - 5/12.

Structure: Four sided pre-fabricated, powder coated steel frame.

Frame: Tubular Steel.

Standard Roof System:

24" Aluminum "W" Panel with Extruded Aluminum Gutters.

Optional Roof System:

36" Galvalume "R" panel with Aluminum Edge Trim, or Optional Gutter.

18" Galvalume Standing Seam Panel with Extruded Aluminum Gutters, or Edge Trim with T&G Wood.

8" Aluminum Roll Formed Flat Panel with Extruded Aluminum Gutters.

Tongue & Groove Wood with Shingles.

Add-On Accessories: Steel railing.



Monoslope Shelters

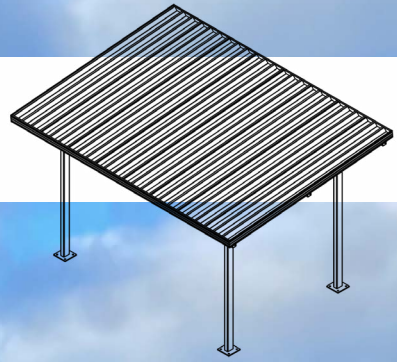

Algonquin Series

If you are looking for a shelter that provides a simple and sleek shade solution for your space, the Algonquin shelter could be the perfect choice for you. This shelter is designed to meet the needs of spaces that require basic shade solutions without compromising on style.

Sizes: Ranging from 10-12' wide and 10-24' long.

Structure: Pre-fabricated, powder coated Aluminum components.

Frame: Extruded Aluminum.

Standard Roof System:

24" Aluminum "W" Panel with Extruded Aluminum Gutters.

Optional Roof System:

8" Aluminum Roll Formed Flat Panel with Extruded Aluminum Gutters.

3" thick Insulated Aluminum Faced Panel with Edge Trim.

Add-On Accessories: Steel railing.

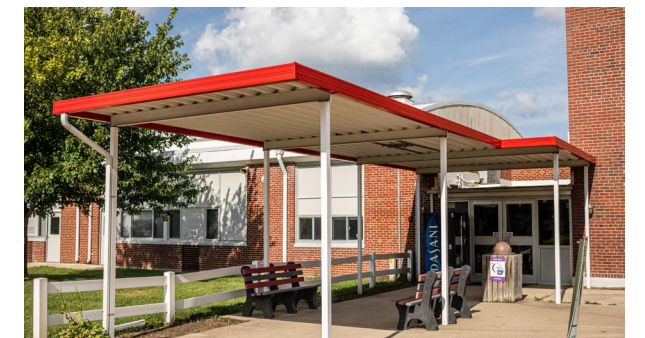

Split Roof Shelters

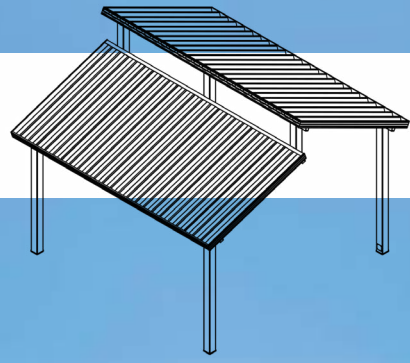

Split Roof Shelters

Presenting the Americana Split Roof Shelter: A striking and functional addition to any outdoor space. Its unique split roof design offers ample coverage while promoting natural airflow, making it perfect for parks, recreational areas, and community gatherings.

Sizes: Ranging from 6-50' wide and 12-84' long.

Roof Pitch: Standard 4/12.

Optional Roof Pitch: 1/12 - 12/12.

Structure: Four sided pre-fabricated, powder coated steel frame.

Frame: Tubular Steel.

Standard Roof System:

24" Aluminum "W" Panel with Extruded Aluminum Gutters.

Optional Roof System:

36" Galvalume "R" panel with Aluminum Edge Trim, or Optional Gutter.

18" Galvalume Standing Seam Panel with Extruded Aluminum Gutters, or Edge Trim with T&G Wood.

8" Aluminum Roll Formed Flat Panel with Extruded Aluminum Gutters.

Tongue & Groove Wood with Shingles.

Add-On Accessories: Steel railing.



Gable Roof Shelters

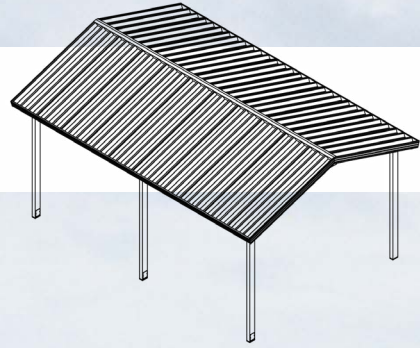

Illini Series

Gable roof shelters rank among the top choices for various applications, including city and community parks, educational institutions, rest stops, as well as residential and commercial endeavors. With sizes spanning from a modest 6' x 12' to a generous 50' x 84', these shelters offer versatile dimensions to suit your needs.

Sizes: Ranging from 6-60' wide and 12-84' long.

Roof Pitch: Standard 4/12.

Optional Roof Pitch: 1/12 - 12/12.

Structure: Four sided pre-fabricated, powder coated steel frame.

Frame: Tubular Steel.

Standard Roof System:

24" Aluminum "W" Panel with Extruded Aluminum Gutters.

Optional Roof System:

36" Galvalume "R" panel with Aluminum Edge Trim, or Optional Gutter.

18" Galvalume Standing Seam Panel with Extruded Aluminum Gutters, or Edge Trim with T&G Wood.

8" Aluminum Roll Formed Flat Panel with Extruded Aluminum Gutters.

Tongue & Groove Wood with Shingles.

Add-On Accessories: Steel railing.



Gable Roof Shelters

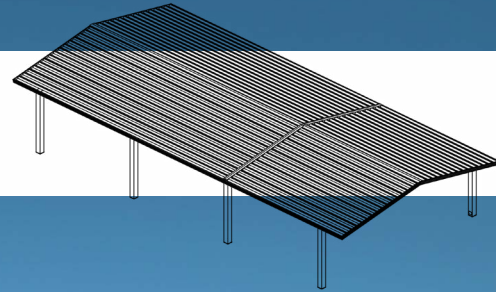

Meramec (DSA) Series

For spaces in need of straightforward shelter, the Meramec is the perfect solution. A classic gable roof design allows the Meramec to be installed in any outdoor environment to provide protection from the elements without detracting from the natural beauty of the space.

Sizes: Ranging from 20-41' wide and 20-54' long.

Roof Pitch: Standard 3/12.

Structure: Four sided pre-fabricated, powder coated steel frame.

Frame: Tubular Steel.

Standard Roof System:

24" Aluminum "W" Panel with Extruded Aluminum Gutters.

Optional Roof System:

3" thick Insulated Aluminum Faced Panel with Edge Trim.

Tongue & Groove Wood with Shingles.

Add-On Accessories: Steel railing



Gable Roof Shelters

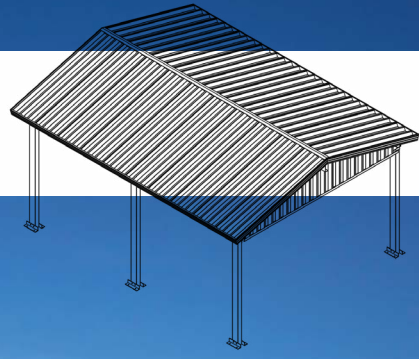

Colonial Series

The Colonial is a sophisticated take on a standard gable roof shelter, with an all-aluminum design, making it perfect for coastal regions. In addition, the gable fill makes this shelter particularly attractive both as a standalone shelter and attached to the façade of building.

Sizes: Ranging from 12-22' wide and 20-40' long.

Roof Pitch: Standard 3/12.

Structure: Pre-fabricated, powder coated Aluminum components.

Frame: Tubular Aluminum.

Standard Roof System:

24" Aluminum "W" Panel with Extruded Aluminum Gutters.

Optional Roof System:

8" Aluminum Roll Formed Flat Panel with Extruded Aluminum Gutters.

3" thick Insulated Aluminum Faced Panel with Edge Trim.

Add-On Accessories: Aluminum Gable Fill kit is included.



Gable Roof Shelters

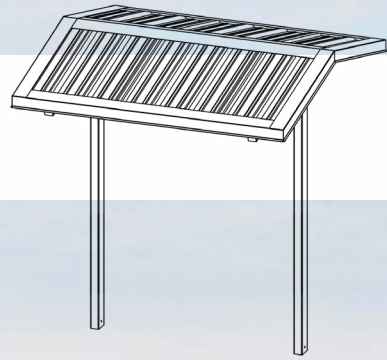

Cherokee Series

Americana Outdoors' Cherokee provides a mix of functionality and shelter, with its double posts acting as a mount for a display board, bench, or table, while also supporting an aluminum roof.

Sizes: Ranging from 8-12' wide and 8-12' long.

Roof Pitch: Standard 3/12.

Structure: Pre-fabricated, powder coated Steel Frame.

Frame: Tubular Steel, or Extruded Aluminum.

Standard Roof System:

24" Aluminum "W" Panel with Extruded Aluminum Gutters.

Optional Roof System:

36" Galvalume "R" panel with Aluminum Edge Trim, or Optional Gutter.

18" Galvalume Standing Seam Panel with Extruded Aluminum Gutters, or Edge Trim with T&G Wood.

8" Aluminum Roll Formed Flat Panel with Extruded Aluminum Gutters.

Add-On Accessories: Bulletin boards, bench, table & bench, double bench.



Gazebo Shelters

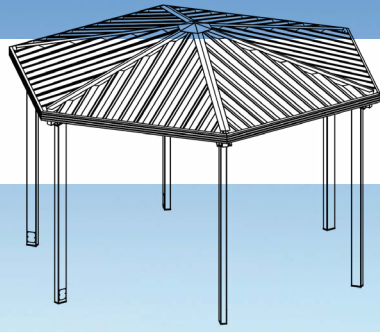

Apache Series

The Apache is Americana's most popular gazebo style shelter, due to the large range of size, style, and color options available. Featuring a six sided design, supported by six posts as standard, with a single post option available.

Sizes: 16-44' Diameter.

Roof Pitch: Standard 3/12.

Optional Roof Pitch: 4/12 - 8/12.

Structure: Hexagonal design, pre-fabricated, powder coated Steel frame.

Frame: Tubular Steel.

Standard Roof System:

24" Aluminum "W" Panel with Extruded Aluminum Gutters.

Optional Roof System:

36" Galvalume "R" panel with Aluminum Edge Trim, or Optional Gutter.

18" Galvalume Standing Seam Panel with Extruded Aluminum Gutters, or Edge Trim with T&G Wood.

8" Aluminum Roll Formed Flat Panel with Extruded Aluminum Gutters.

Tongue & Groove Wood with Shingles.

Add-On Accessories: Cupola, Double Tier Roof, Steel Railing, Benches.



Gazebo Shelters

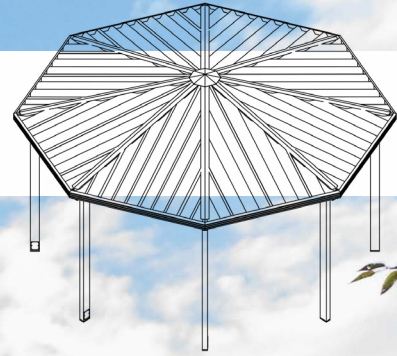

Aztec Series

The Aztec shelter delivers expansive coverage with a sleek design. Featuring Americana's patented "W" roofing panels, the eight-sided roof boasts enhanced rigidity and capability, requiring fewer panels than competitors' systems.

Sizes: 16-54' Diameter.

Roof Pitch: Standard 3/12.

Optional Roof Pitch: 4/12 - 8/12.

Structure: Octagonal design, pre-fabricated, powder coated Steel frame.

Frame: Tubular Steel.

Standard Roof System:

24" Aluminum "W" Panel with Extruded Aluminum Gutters.

Optional Roof System:

36" Galvalume "R" panel with Aluminum Edge Trim, or Optional Gutter.

18" Galvalume Standing Seam Panel with Extruded Aluminum Gutters, or Edge Trim with T&G Wood.

8" Aluminum Roll Formed Flat Panel with Extruded Aluminum Gutters.

Tongue & Groove Wood with Shingles.

Add-On Accessories: Cupola, Double & Triple Tier Roof, Steel Railing, Benches.



Entryway Shelters

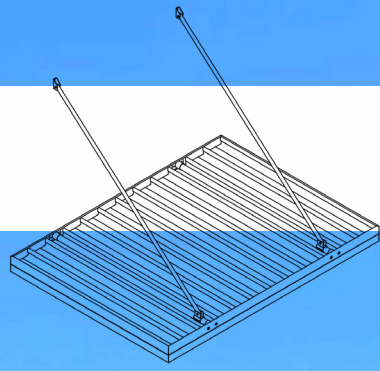

Imperial Hanger Rod Canopy Series

Imperial Hanger Rod Canopies are designed to elegantly cover building entryways. This sophisticated canopy offers protection from the elements while enhancing curb appeal. Expertly crafted and durable, the Imperial is a stylish and functional addition to any entrance, ensuring a welcoming experience for visitors and occupants alike.

Sizes: Ranging from 2' 6"-10' projection and 4'-25'+ wide. Widths upwards of 1000'+ with splices.

Structure: Pre-fabricated, powder coated Aluminum components.

Gutters / Fascia: Extruded Aluminum, 6", 8", or 12" fascia with 4" gutter.

Standard Roof System:

24" Aluminum "W" Panel with Extruded Aluminum Gutters.

Optional Roof System:

6" Aluminum Extruded Flat Panel, with Extruded Aluminum Gutters.

8" Aluminum Roll Formed Flat Panel with Extruded Aluminum Gutters.

10" Aluminum Roll Formed "V" panel.

1.5" square Aluminum Extruded Lattice.

Supports: Overhead "Hanger Rod" braces.

Add-On Accessories: Crown Molding.

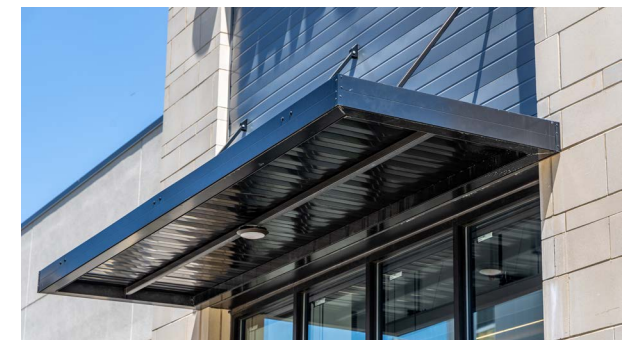

Entryway Shelters



Imperial Post Supported Canopy Series

Imperial Post Supported Canopies are designed to elegantly cover building entryways. This sophisticated canopy offers protection from the elements while enhancing curb appeal. Expertly crafted and durable, the Imperial is a stylish and functional addition to any entrance, ensuring a welcoming experience for visitors and occupants alike.

Sizes: Ranging from 2' 6"-10' projection and 4'-25'+ wide. Widths upwards of 1000'+ with splices.

Structure: Pre-fabricated, powder coated Aluminum components.

Gutters / Fascia: Extruded Aluminum, 6", 8", or 12" fascia with 4" gutter.

Standard Roof System:

24" Aluminum "W" Panel with Extruded Aluminum Gutters.

Optional Roof System:

6" Aluminum Extruded Flat Panel, with Extruded Aluminum Gutters.

8" Aluminum Roll Formed Flat Panel with Extruded Aluminum Gutters.

10" Aluminum Roll Formed "V" panel.

1.5" square Aluminum Extruded Lattice.

Supports: Extruded Aluminum Posts.

Add-On Accessories: Crown Molding.



Entryway Shelters

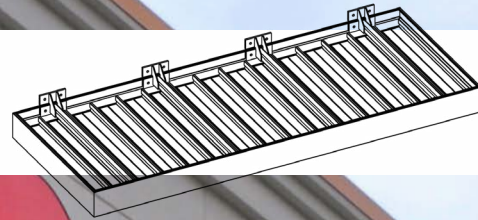

Imperial Cantilever Canopy Series

Imperial Cantilever Canopies are designed to elegantly cover building entryways without any visible supports, providing a "floating" stylization. This sophisticated canopy offers protection from the elements while enhancing curb appeal. Expertly crafted and durable, the Imperial is a stylish and functional addition to any entrance, ensuring a welcoming experience for visitors and occupants alike.

Sizes: Ranging from 2' 6"-10' projection and 4'-25'+ wide. Widths upwards of 1000'+ with splices.

Structure: Pre-fabricated, powder coated Aluminum components.

Gutters / Fascia: Extruded Aluminum, 6", 8", or 12" fascia with 4" gutter.

Standard Roof System:

24" Aluminum "W" Panel with Extruded Aluminum Gutters.

Optional Roof System:

6" Aluminum Extruded Flat Panel, with Extruded Aluminum Gutters.

8" Aluminum Roll Formed Flat Panel with Extruded Aluminum Gutters.

10" Aluminum Roll Formed "V" panel.

Supports: "Hidden" Cantilever Mounts.

Add-On Accessories: Crown Molding.



Walkway Shelters

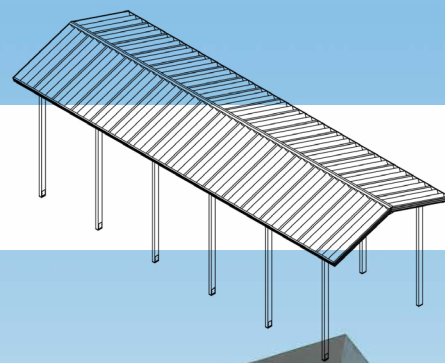

Walkway Shelters

Whether you need to protect your guests from the sun, rain, or snow, our Walkway Shelters are the perfect solution. With a range of sizes, styles, and colors to choose from, we're confident that we have the perfect shelter to suit your needs.

Sizes: Ranging from 6-50' wide and 10-80' long.

Roof Pitch: Varies depending on structure needs.

Structure: Pre-fabricated, powder coated Steel components.

Frame: Tubular Steel.

Standard Roof System:

24" Aluminum "W" Panel with Extruded Aluminum Gutters.

Optional Roof System:

36" Galvalume "R" panel with Aluminum Edge Trim, or Optional Gutter.

8" Aluminum Roll Formed Flat Panel with Extruded Aluminum Gutters.

6" Aluminum Extruded Flat Panel, with Extruded Aluminum Gutters.

Add-On Accessories: Steel railing.

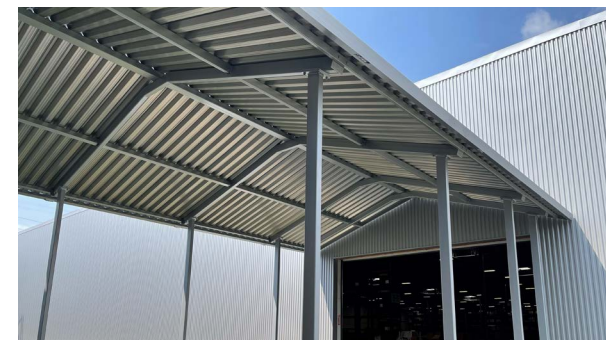

Cantilever Shelters

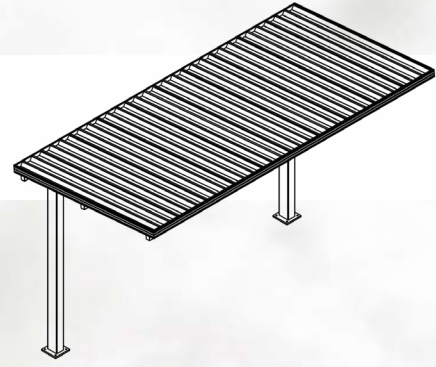

Shawnee Series

Shawnee Shelters are designed with dugouts specifically in mind, giving you a product that will keep your team protected no matter the weather on game day. Our project managers work with customers to create a perfect sized Shawnee for any sport site needs.

Sizes: Varies depending on application and structure needs.

Structure: Pre-fabricated, powder coated steel frame.

Frame: Tubular Steel.

Standard Roof System:

24" Aluminum "W" Panel with Extruded Aluminum Gutters.

Optional Roof System:

36" Galvalume "R" panel with Aluminum Edge Trim, or Optional Gutter.

18" Galvalume Standing Seam Panel with Extruded Aluminum Gutters, or Edge Trim with T&G Wood.

8" Aluminum Roll Formed Flat Panel with Extruded Aluminum Gutters.

Tongue & Groove Wood with Shingles.

Add-On Accessories: Steel railing, Extruded Aluminum Benches/Bleachers.



Shade Shelters

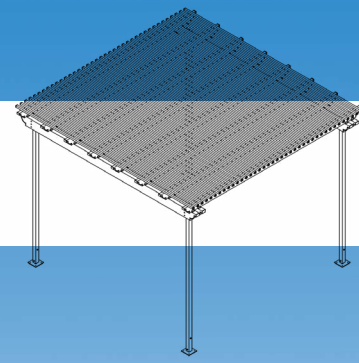

Pergola Series

The Americana Outdoors® line of pergola products are the perfect addition to any outdoor environment. The timeless, elegant design complements any exterior space, adding the ideal amount of shade, while not obstructing your view of nature. Our pergolas are available in multiple sizes and colors to best serve your space.

Sizes: Custom designed to fit your application.

Structure: Pre-fabricated, powder coated Aluminum components.

Frame: Tubular Steel or Extruded Aluminum.

Header Options:

- Curved, or Straight Steel
- Extruded Aluminum
- 3x8" Wood Grain Embossed Aluminum

Roof Options:

- Wood Grain Embossed Aluminum Lattice
- Round Extruded Aluminum Tubes
- Laser Cut Aluminum Panels (Multiple Designs Available).

Add-On Accessories: Fabric Drapes, Roll-Up Curtains.



Shade Shelters

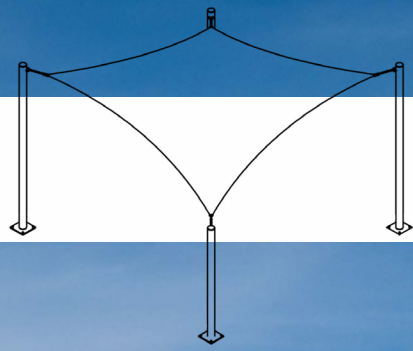

Shade Sail Series

The Americana Outdoors® line of pergola products are the perfect addition to any outdoor environment. The timeless, elegant design complements any exterior space, adding the ideal amount of shade, while not obstructing your view of nature. Our pergolas are available in multiple sizes and colors to best serve your space.

Sizes: Custom designed to fit your application.

Structure: Pre-fabricated, powder coated Steel components.

Frame: Tubular Steel.

Fabric: Maintenance-free high strength 100% HDPE round yarn.

Fabric Top: Designed to withstand high winds.

Optional Roof Options: 10 Vibrant colors available.

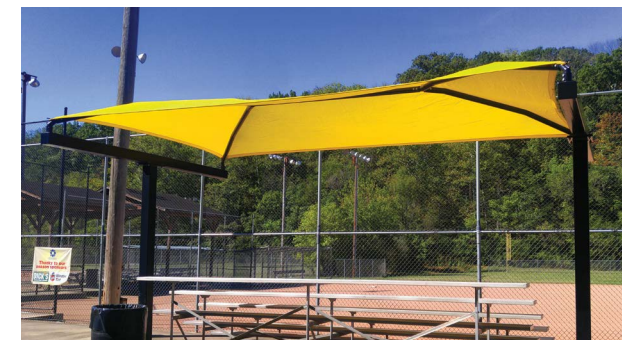



Railing Options

Railings are a great way to add a unique touch to your structure and can be incorporated into most designs. There are several standard designs available, inspired by common architectural styles, and customized designs are available to suit your project's needs. Top Railings are 12" tall, Bottom Railings are 42" tall, made from 3/16" thick steel.

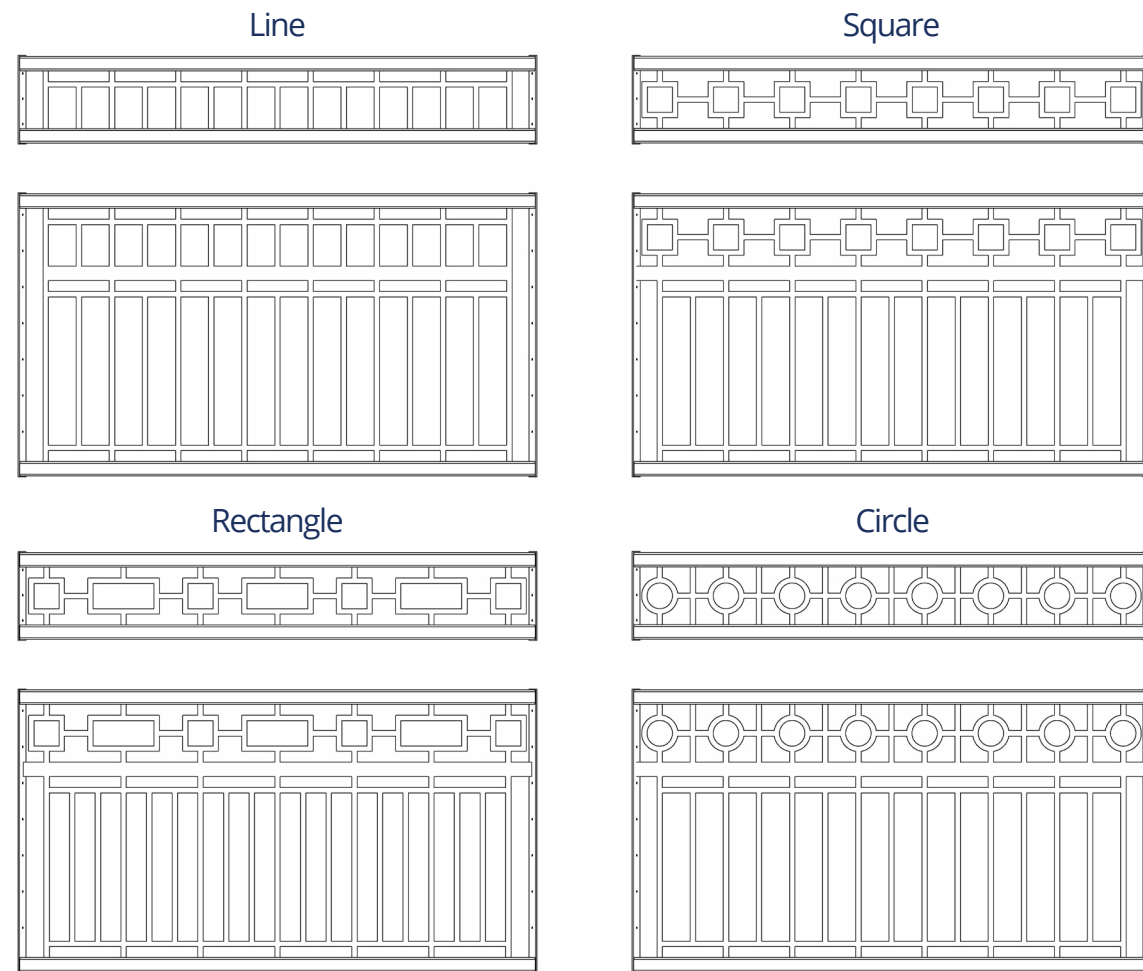

Cupola, Clerestory, & Gable Options

Our Cupolas, Clerestories, & Gables are designed to add natural light, ventilation, and a touch of elegance to your shelter. The Cupolas come standard with an Open design, or an optional Louvered panel. We also offer a fully customizable, laser cut panel option for the Cupolas, Clerestories, & Gables. Which is ideal for displaying logos, affiliations, or project sponsors.

Cupola Options

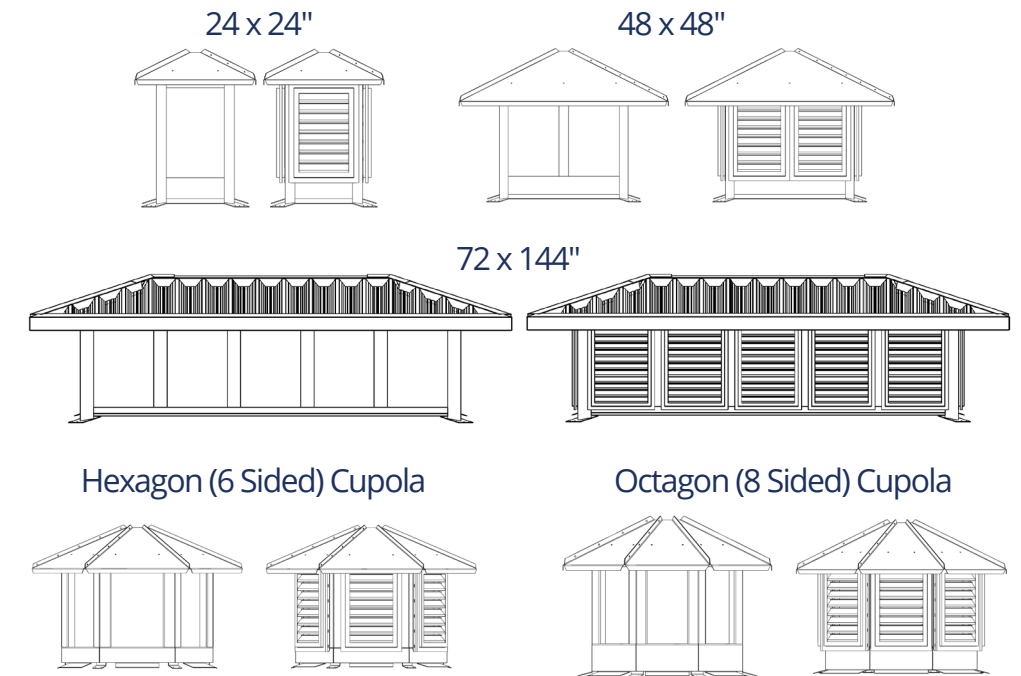

Clerestory & Gable Examples





Frame & Post Style

Americana Shelters feature American-made steel tubular frames, pre-drilled for easy bolt-together assembly, and detailed instructions that reduce installation costs. Fasteners are zinc-plated, galvanized, or stainless steel to prevent rust and stains.

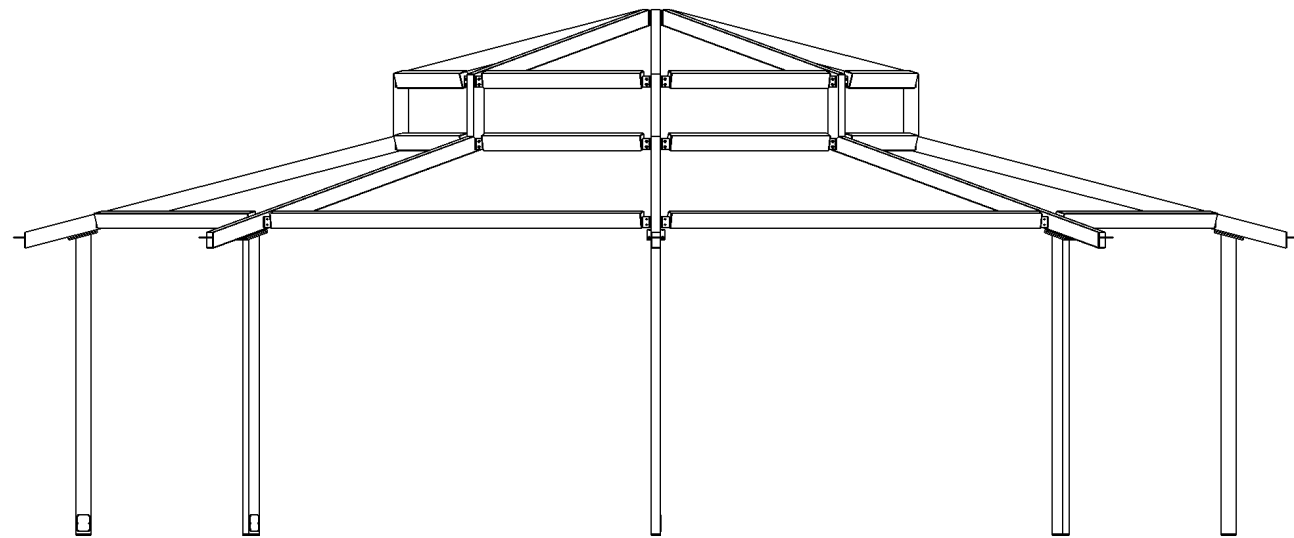

Standard Post Base Plate Connections

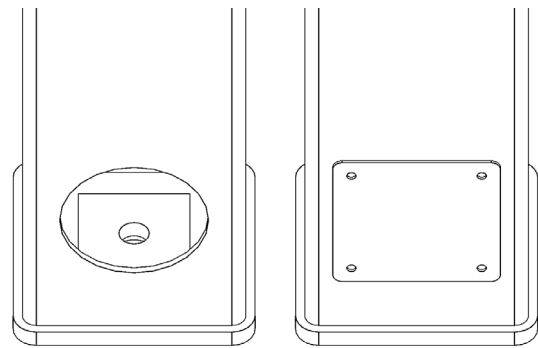

Internal Anchor Bolt with Cover Plate

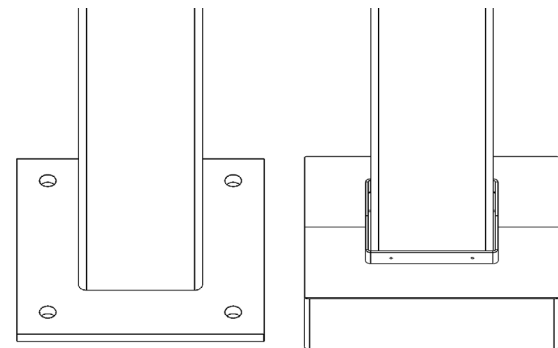

External Anchor Bolts with Optional Cover

Roof Panel Colors & Options

We take great pride in producing a majority of our roof panel options in-house, which gives us complete control over the quality and production schedule. By doing so, we are able to provide our customers with top-notch products while also passing on cost savings.

24" Aluminum Structural "W" Panel

Features:

Structural roof panel designed to limit the amount rafters & purlins per structure.

Best overall value when comparing cost & strength.

Gutters are included for water erosion management.

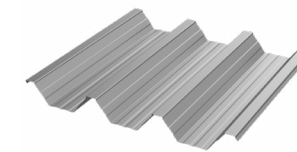

Coverage Width - 24"
Minimum Slope - 1/2:12
Thickness - .038" & .024" (560 Anodized Only)
Finish - Stucco Embossed
Coatings - DuraCoat XT40 Ceranamel
Rib Spacing - 8" on center
Rib Height - 2-1/2"
Compatible with all model shelters except for Pergola



36" Galvalume® 26 Gauge "R" Panel

Features:

Flush fit for a cleaner, sleeker appearance.

Designed to deter bird roosting.

Edge trim is included for a simple & flawless finish.



Coverage Width - 36"
Minimum Slope - 1/2:12
Gauge - 26
Finish - Smooth
Coatings - Siliconized Polyester
Rib Spacing - 12" on center
Rib Height - 1-1/4"
Compatible with all model shelters except for Meramec, Colonial & Pergola

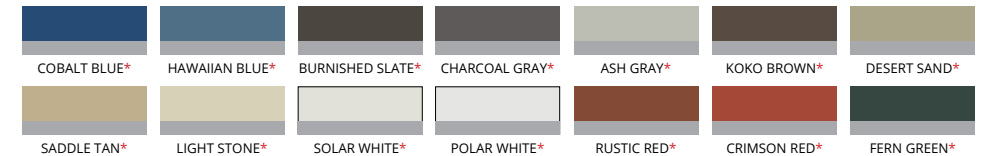

Colors containing asterisks have a wash coat bottom side

18" Galvalume® 24 Gauge Standing Seam Panel

Features:

Flush fit for a cleaner, sleeker appearance.

Designed to deter bird roosting.

Gutters are included for water erosion management. Edge trim is standard with tongue and groove wood substructures applications.

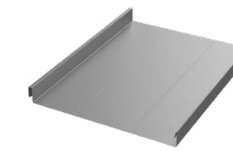

Coverage Width - 18"
Minimum Slope - 1/2:12
Gauge - 24
Finish - Smooth
Coatings - Siliconized Polyester
Rib Spacing - N/A
Rib Height - 1-3/4"
Compatible with all model shelters except for Meramec, Colonial, & Pergola

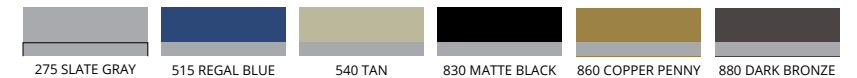

Each color has a wash coat on the underside, paired with an inked date stamp for manufacturer warranty verification.

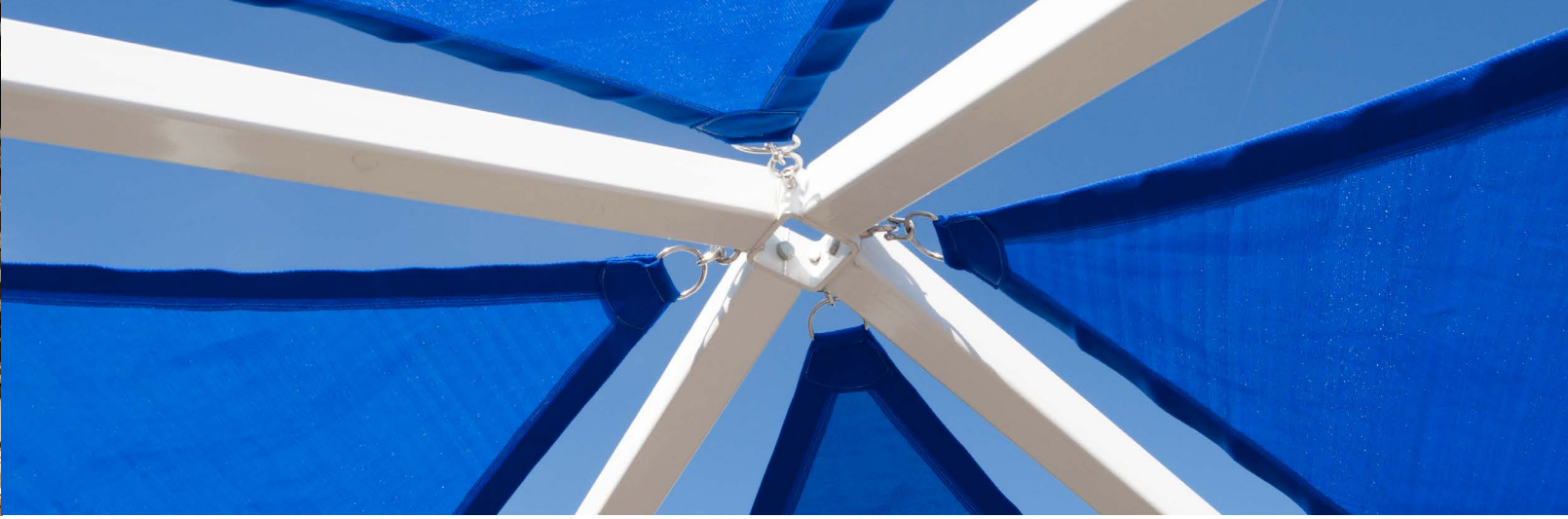

Roof Panel Colors & Options

We take great pride in producing a majority of our roof panel options in-house, which gives us complete control over the quality and production schedule. By doing so, we are able to provide our customers with top-notch products while also passing on cost savings

8" Aluminum Structural Flat Panel

Features:

Flush fit for a cleaner, sleeker appearance.

—
Designed to deter bird roosting.

—
Gutters are included for water erosion management.

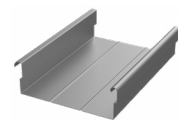

Coverage Width - 8"
Minimum Slope - 1/2:12
Thickness - .024", .032", & .040"
Finish - Smooth Matte Finish
Coatings - DuraCoat XT40 Ceranamel
Rib Spacing - N/A
Rib Height - 2-5/8"

Compatible with all model shelters except for Meramec & Pergola



6" Aluminum Extruded Flat Panel

Features:

Flush fit for a cleaner, sleeker appearance.

—
Designed to deter bird roosting.

—
Gutters are included for water erosion management.

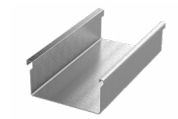

Coverage Width - 6"
Minimum Slope - 1/2:12
Thickness - .065"
Finish - Smooth Gloss Finish
Coatings - Super Durable Polyester
Rib Spacing - N/A
Rib Height - 2-7/8"

Compatible only with Walkways & Entry Covers



Powder coat finish available in all frame colors. Full RAL color palette available at additional cost.

3" Thick Insulated Aluminum Panel White stucco finish with foam core

Features:

Insulated panels for noise and temperature control.

—
Flush fit for a cleaner, sleeker appearance.

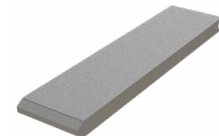

Compatible with all model shelters except for Cherokee, Pergola, Walkways & Entry Covers

Tongue and Groove Wood

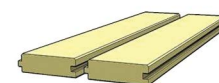

1) Southern Yellow Pine
2) Western Cedar

Utilized as sub roofing for shelters using the 18" standing seam panels or shingles.

Frame & Fabric Color Options

Our Americana Industrial Coatings division enables us to powdercoat all of our products in-house, setting us apart from our competitors. This grants us complete authority over pricing, quality, and production times, allowing us to transfer these benefits to our customers.

Super Durable Frame Color Options



Super Durable & Anti Graffiti Frame Color Options



Fabric Shelter Color Options

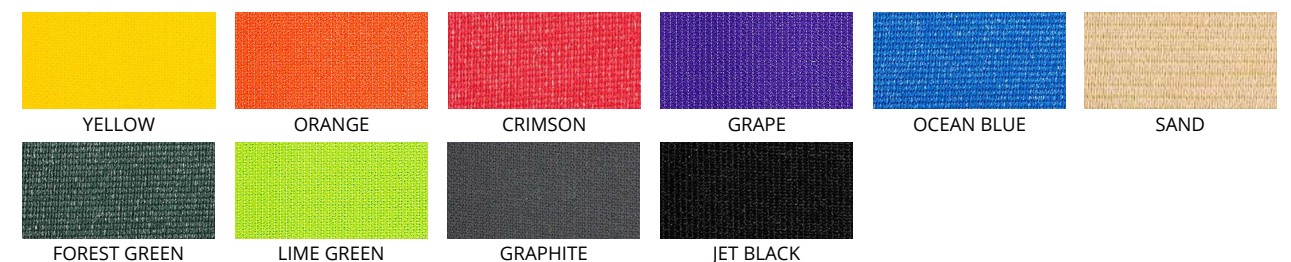

Sales & Installation Support

Design and engineering support and documentation to satisfy local requirements: Heavy Snow, Seismic, High Winds, Hail, Custom Designs & Sizes.

Average standard lead times are 6-8 weeks from receipt of approved order. Lead times may vary on design criteria.

Installation and sales support available M-F (8am-5pm) central standard time.

Since Americana is a custom manufacturer, non-standard items are routinely fabricated with no delays. Minimal extra charges may be incurred for engineering.

Warranty Terms

Lifetime Limited Warranty

Lifetime Limited Warranty on aluminum against material failure and corrosion.

25 Year Limited Warranty

25 Year Limited Warranty on steel against material failure and defects.

10 Year Limited Warranty

10 Year Limited Warranty on Sunbrella, Sheerweave, & Solamesh Fabrics

10 Year Limited Warranty on all powder coat finishes (200, 500 and 800 series).

With the use of Americana's 500 Series Anti-graffiti powder coat finish is guaranteed to allow removal of graffiti with virtually no change to the finish.

5 Year Limited Warranty

5 Year Limited Warranty on Soltis 86 fabrics.

1 Year Warranty

1 Year warranty against defects in materials and workmanship.

Period of Coverage:

The warranty period begins on the date of the original shipment.

What Americana Will Do To Correct Problems:

If defects or damage of the kind mentioned above should occur within the warranty period, Americana will replace the defective parts only; FOB its plant at Salem, Illinois, upon receiving the written and documented claim of the purchaser.

Warranty Exclusions:

Because of the normal aging and weathering of materials, it may not be possible to perfectly match the colors of original parts and replacement parts. Americana will not provide or pay for the installation of such replacement parts. Americana shall not be responsible for weather-related failures, damages due to faulty installation, misuse or abuse of the product, or for consequential damages, including personal injuries or property damages. There are no warranties, express, or implied, which extend beyond the description on the face hereof.

How To File A Warranty Claim:

If you believe that you have a claim under this warranty, submit a copy of your original receipt or other reasonable evidence of the date of purchase, the identity of the product, and photos and a description of the allegedly defective product to the address below. Please also include your name, address, and phone number so that a customer service representative can respond to your submission. The ultimate determination of the existence and extent of any claimed defect under this warranty shall be made by Americana in its sole discretion.

Submit Claims To:

Americana Outdoors, Inc, Warranty Claim
P.O. Box 1290
Salem, IL 62881



Looking for Premium Quality Site Furnishings to complement your new shelter? Do you need field or sports court equipment to help the games happen? PW Athletic & LA Steelcraft, subsidiaries of Americana Outdoors have you covered!

Our selections of various site furnishings and sports equipment are a perfect match to the craftsmanship and quality of the Americana Outdoors shelters. Like our shelter products, our site furnishings and sports equipment are 100% made in the U.S.A. and have the best warranties in the industry.

For more information give us a call on 1-888-442-2925 or visit our website at www.PWathletic.com or www.LASteelcraft.com



PO Box 1290, Salem IL 62881
1-800-851-0865, Fax: 1-618-548-2890
Sales@Americana.com
www.Americana.com



2024 SHELTER CATALOG